

**Office of the Dean Research and Development
Indian Institute of Engineering Science & Technology (IEST), Shibpur
Howrah-711 103**

Project Code: DRC/MHRD-IITKGP/DIC/SB/014/16-17

**Department of Aerospace Engineering and Applied Mechanics
Indian Institute of Engineering Science & Technology (IEST), Shibpur
Howrah-711 103**

National Initiative on Design Innovation

Tender Advt. No.: AM 1353 , dated 19.02.2018

Ref.: DIC/SB/03 dated 16/02/2018

Notice Inviting Quotations

Notice inviting sealed quotations from manufacturers, suppliers and agents for fabrication /supply /development of the following item as mentioned below:

Item No. 1: Complete Fabrication of a Jute Fibre Extraction Machine as per drawing including head rammer, rollers, jute head cutter, gripper, conveyor belt, structural frame etc.

Quantity: 1 no. (complete setup) Material: Mild steel

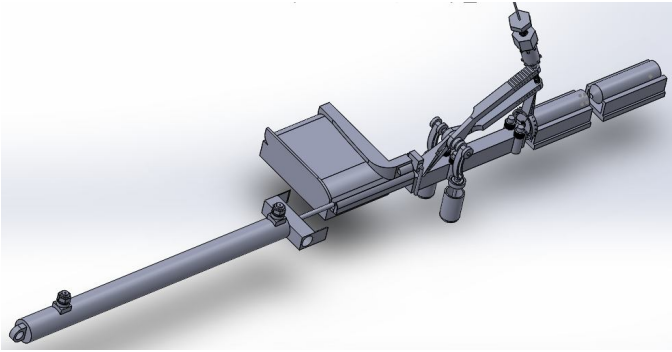

All mechanical parts of the Jute Fibre Extraction Machine should be fabricated and assembled as per the drawing. Details may be available from:

Dr. Subhasis Bhaumik

(Email: sbhaumik_besu@yahoo.co.in,
subhasis@aero.iests.ac.in

Mobile No. - 9836044278).

All mechanical parts should be included in the system in assembled condition. The system should have smooth proper surface finish with appropriate coating.

The price quoted should be inclusive of all Taxes in INR, duties and levies. Inclusion of Tax/Levy at a later stage will not be accepted. Freight, Insurance charges should be clearly indicated. If GST is chargeable then price quoted should be inclusive of GST in INR.

The sealed signed quotation along with GST certificate, PAN, valid Trade license (current), should be submitted to Prof. Subhasis Bhaumik, Coordinator - National Initiative on Design Innovation, Department of Aerospace Engineering & Applied Mechanics, Indian Institute of Engineering Science & Technology, Shibpur, Howrah - 711103, West Bengal, INDIA

Deliver time: Within 10 days from the date of placement of order.

Last date of submission of quotation: 26.02.2018 (Monday) upto 2.00 p.m.;

Date of opening of quotation: 26.02.2018 (Monday) at 3.00 p.m.

Indian Institute of Engineering Science and Technology (IEST), Shibpur, Howrah reserves the right to accept/ reject all or any of the tenders without assigning any reason whatsoever.

Dean (R & D)

(A. Code DRC-T132/17-18)